

## Cylinder Pressure Sensor HTT-04®

*for On-line Combustion control*

Cylinder pressure sensor for on-line combustion control on diesel- and gas engines for increasing engine performance and optimised engine control.

### Characteristics

- Designed life expectancy of 16,000 h
- Digital electronic with event storing
- Very good thermodynamic performance

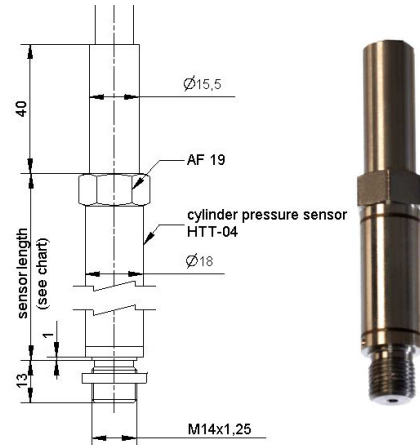

### Application:

Closed loop control on internal combustion engines e.g. knock detection, cylinder balancing, MIP calculation, start of combustion, NOx control

### Technical data

Measuring range pressure	0...300 bar
Over pressure static	1200 (option- 1500 bar)
Frequency range	2 kHz (others on request)
Thermal shock 1500 RPM pmi=10bar	< +/- 0,5 bar
Accuracy	≤1% Full scale
Max. temperature at measuring cell	300 °C (short time 1 min 350°C)
Temperature range of SCU	-40 °C ... + 75 °C
Supply voltage	18...32 VDC
SCU current consumption	≤50 mA (continuous operation); 250 mA (switch-on peak)
Output signal range	4...20 mA
Electrical connector	Plug DIN M12
Thread	M14 x 1,25
Dimension sensor	52 mm , Ø 18 mm
Dimension electronic	115 mm x 18 mm
Tightening torque	25 Nm
Weight incl. electronic	325 g

## General specifications

Degree of protection	IP 67 (EN 60529)
CE approval	2004/1008/EG EN 61000-6-2 EN 61000-6-4 EN 61326-1
ATEX type approval	Group II, Category 3G

Optimum sensor life is achieved at an average temperature at the measuring element of 200 - 250 °C.

The life expectancy of the sensor has been designed so that the lifetime of 16.000 h or more can be achieved in a gas engine. at 1500 rpm.

## Mounting

The sensor should be installed close to the combustion chamber, the length of the pressure bore between sensor and combustion chamber depends mainly on engine speed.

Generally there are two possibilities for the installation position of cylinder pressure sensors:

Head mounted or set-back mounted.

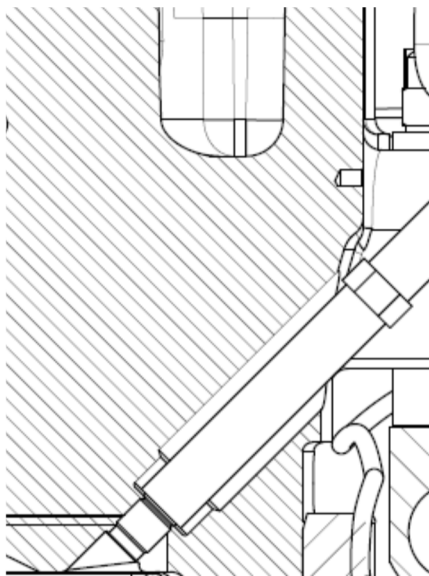

Head mounted installation near to combustion chamber

## Connector

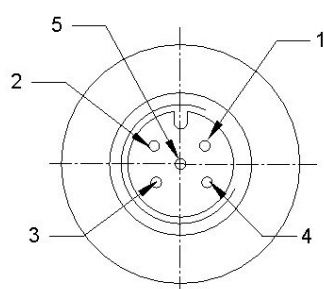

1 = supply

3 = pressure signal

4 = signal zero point AGND

5 = programming pin (only used for calibration)

2 = not connected

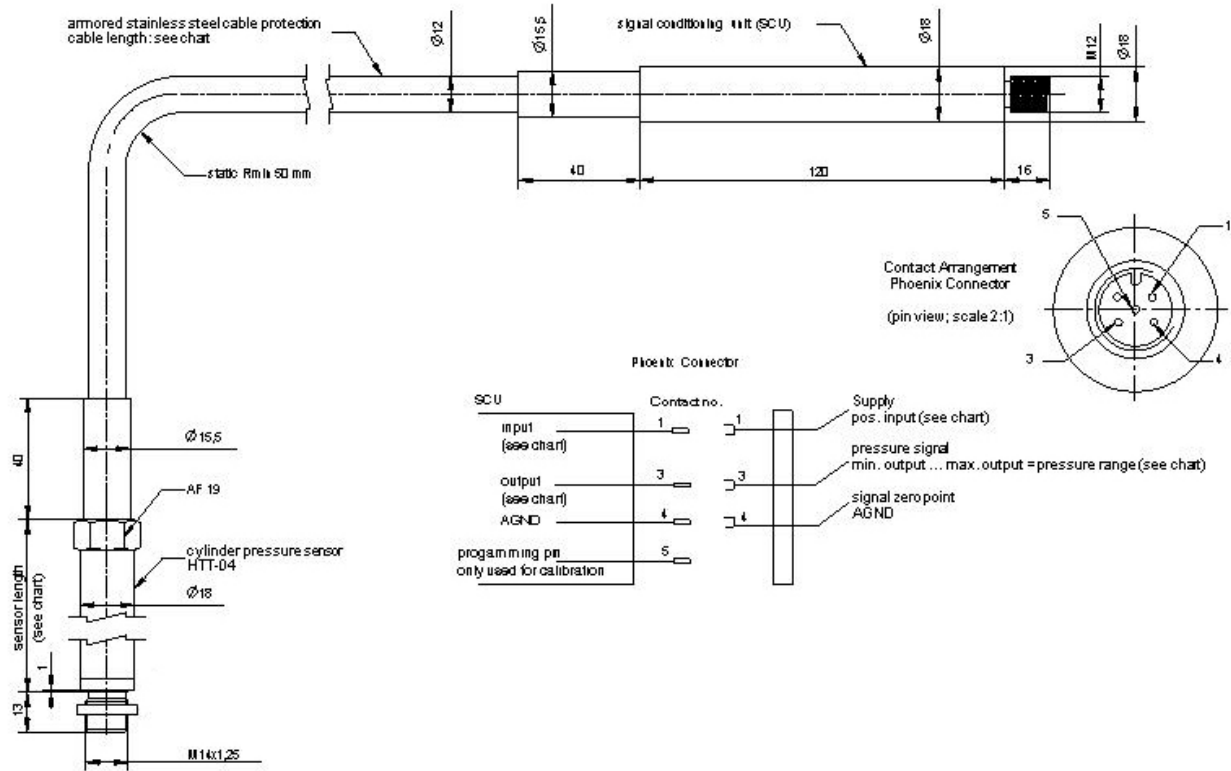

Product No.	Pressure range	Sensor length	Cable length	Static overpressure
IW-6231	0 - 300 bar	105 mm	0,4 m	1200 bar
IW-6232	0 - 300 bar	105 mm	0,4 m	1500 bar
IW-6237	0 - 300 bar	52 mm	0,4 m	1200 bar
IW-6238	0 - 300 bar	52 mm	0,4 m	1500 bar

### Optional Accessories

Protection cover

Connecting cable 5m

Connecting cable 10m

### Product No.

IW-6210

IW-4110

IW-4111